

Install Instructions

# XFrame Classic Booth

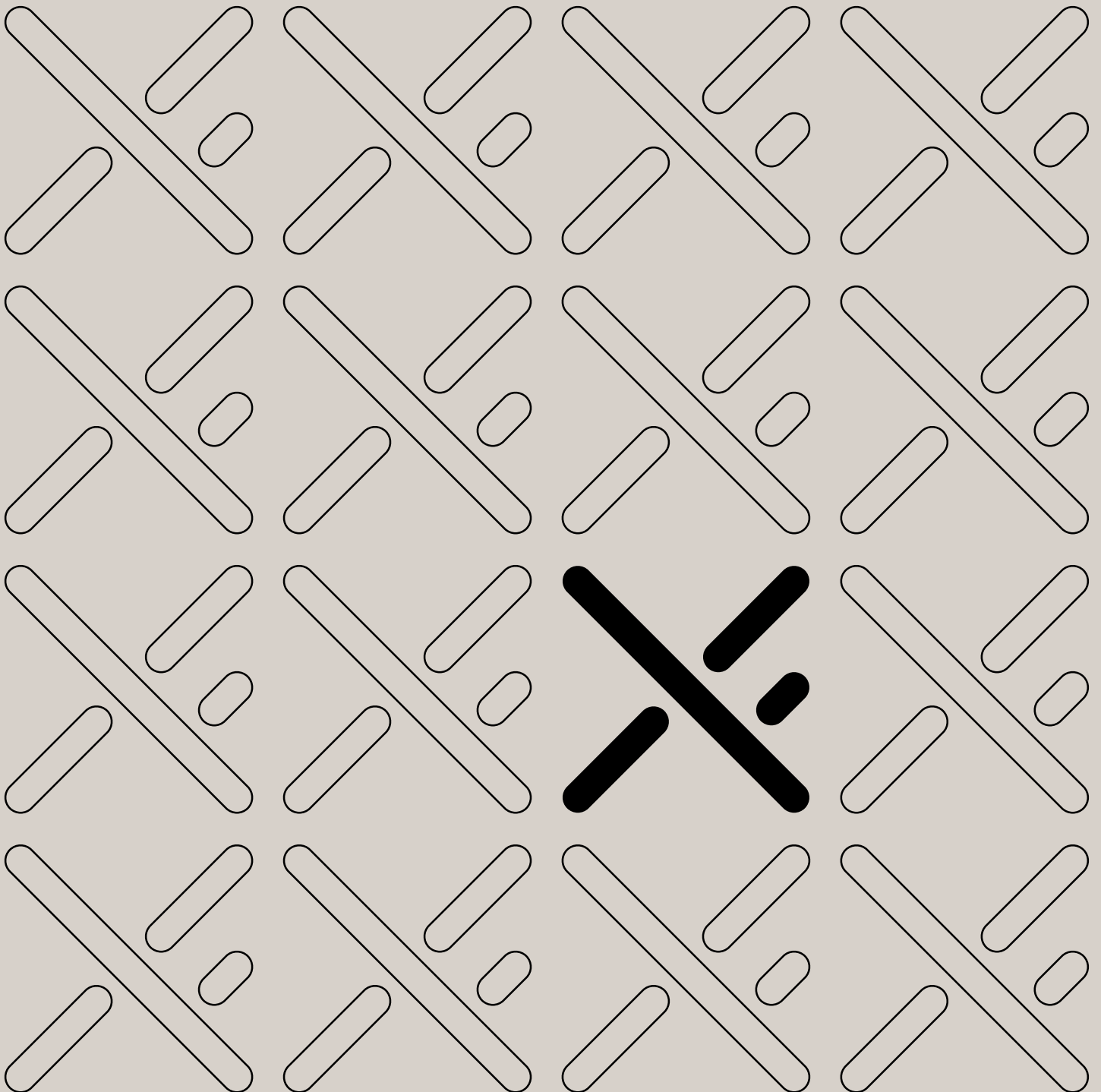



XFrame PTY Ltd, 1 Tonsley Boulevard, Adelaide, Australia.

XFrame products are designed in Wellington, New Zealand.

Copyright XFrame PTY Ltd.

All images are the exclusive property of XFrame PTY Ltd.

'XFrame' and the XFrame logo are registered trademarks of XFrame PTY Ltd.

For more information, please inquire at [support@xframe.com.au](mailto:support@xframe.com.au)

**Designed for now,  
built for later.**



# Assembly Health and Safety



*Assemble  
With Care*



*Ear Protection  
Optional*



*Hand Protection  
Recommended*



*Lift Correctly  
With Care*

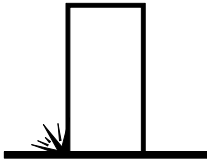

**Protect  
Surfaces**



**Two Persons  
Assembly**



**Do Not Climb  
on XFrame**

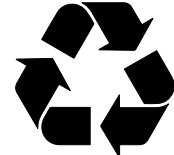

**Recycle All  
Packaging**

Follow all instructions with care. Handle all components with care. Do not assemble the product without following these assembly instructions provided by this guide.

XFrame Office systems are made of untreated engineered timber materials. During assembly use gloves to protect hands from splinters. During use avoid abrasive materials dislodging wood fragments causing splinters and/or damaging clothing/the product. All engineered timber used in XFrame Office systems are to ISO 12460 standards.

XFrame Office systems are made of untreated engineered timber materials that contain phenol formaldehyde resins. Only engineered sheet products with an emission class of 0 or better is used in XFrame Office products.

XFrame Office systems must be assembled with the aid of a rubber or wooden mallet (provided). When using this aid take all necessary best-practice safety precautions. Do not use a hammer that is damaged. Wear eye protection. Do not use a metal faced hammer or black rubber faced mallet.

XFrame Office systems are heavy once assembled and safe lifting requirements must be maintained at all times. Unlined XFrame panels measuring up to 8ft by 4ft (1.2m x 2.4m) may be lifted by an individual. Lined panels, joined panels and/or panels of a greater dimensions must be moved by at least two people.

When standing, joining and/or connecting XFrame™ panels ensure care is taken to ensure each panel is always supported. Do not leave single panels standing without perpendicular or intersecting panels fully connected. Ensure hands and fingers are clear of panel joints when connecting panels.

For the protection of the product, and to protect the objects and surfaces near your product, it is recommended that the product is placed on a protected surface during assembly (such as carpet or carpet tiles).

All XFrame Office products are designed for indoor use only.

Do not stand on XFrame Office products and do not use XFrame office products as a step-ladder.

During assembly take care to not over tighten or use excessive force as this may damage the product.

Where possible assemble the XFrame furniture items near the area in which they will be placed to avoid moving the item unnecessarily.

XFrame furniture items are large and require ample space for assembly. Please ensure that you have sufficient space before beginning.

Ensure all parts are present before assembling. If parts are missing please contact XFrame™.





# Part Overview (1)

## Wall Panels, Linings and Cappings

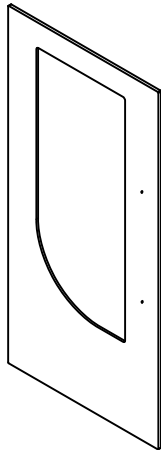

**Door**

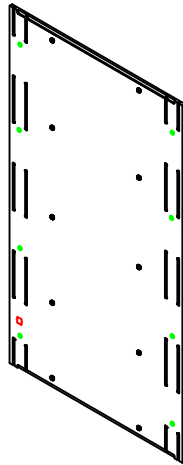

**Back wall**

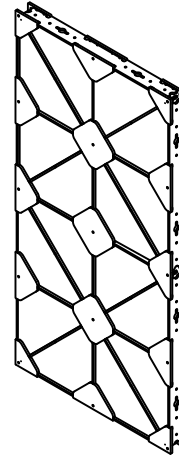

**Right wall frame**

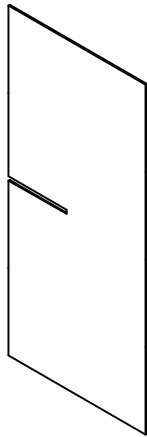

**Interior back wall lining**

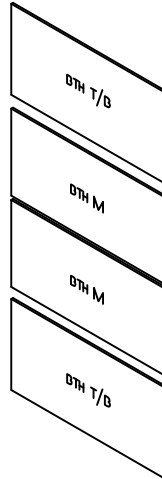

**External side wall lining**  
(4 panel option)

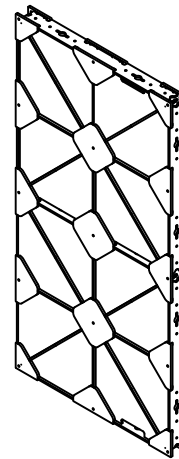

**Service Wall Frame**  
(Holds electrical kit)

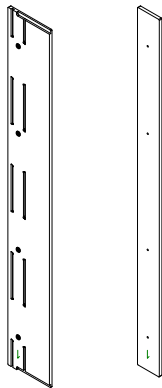

**End Cappings**  
(Right wall)

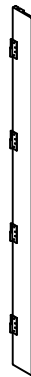

**Hinge capping**  
(Service wall holding  
electrical kit)

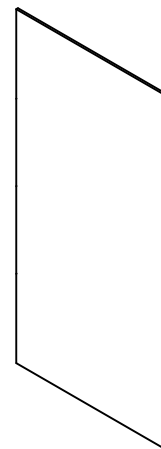

**External side wall lining**  
(1 full panel option)



# Part Overview (2)

## Small Parts

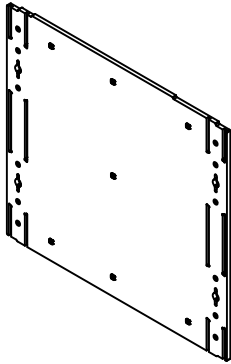

**Roof**  
Code: BTH RF

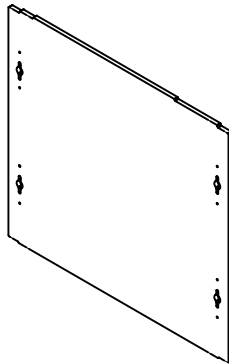

**Floor**  
Code: BTH FLR

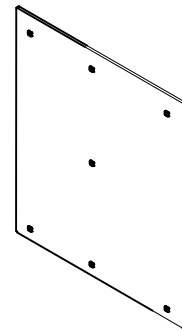

**Roof Acoustic Lining**

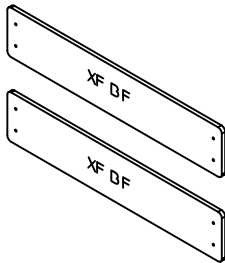

**Feet**  
Code: XF BF

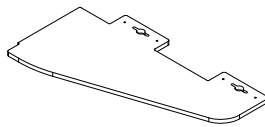

**Desk**

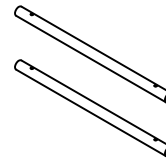

**DoorHandles**





# Fixings and other Small Hardware

Screws, bolts, magnets, washers.

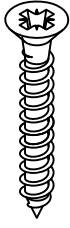

**12mm (1/2 inch) Black CS Hinge Screws x 38**



**40mm M6 Stand-Offs (ZP) x 4**

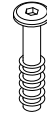

**35mm M6 JCB's x 4**

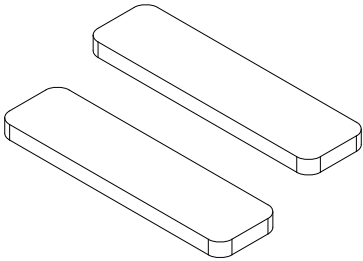

**Door Magnets x 2**  
Pre-installed

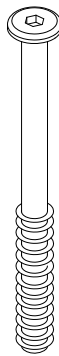

**90mm JCB x 30**  
Pre-installed

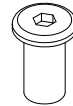

**20mm JCN x 30**  
Pre-installed

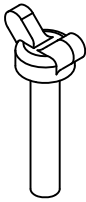

**25mm M6 Wing Screw x 34**

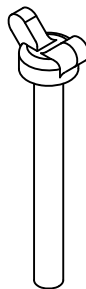

**40mm M6 Wing Screw x 14**

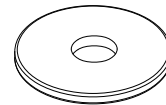

**32mm Penny Washers x 42**



**M6 Hex Nuts x 4**



**15mm Black Screw x 2**





# Step 1

## Connect side walls to back wall.

Using 25mm M6 Wing screws and washers connect XFrame sides one at a time to the back panel on the ground. Repeat this process on both sides.

**Note:** Removing insulation will make installing wing-screws easier. It is recommended that flooring surfaces are protected during assembly.

**Service wall frame**  
(Holds electrical kit)

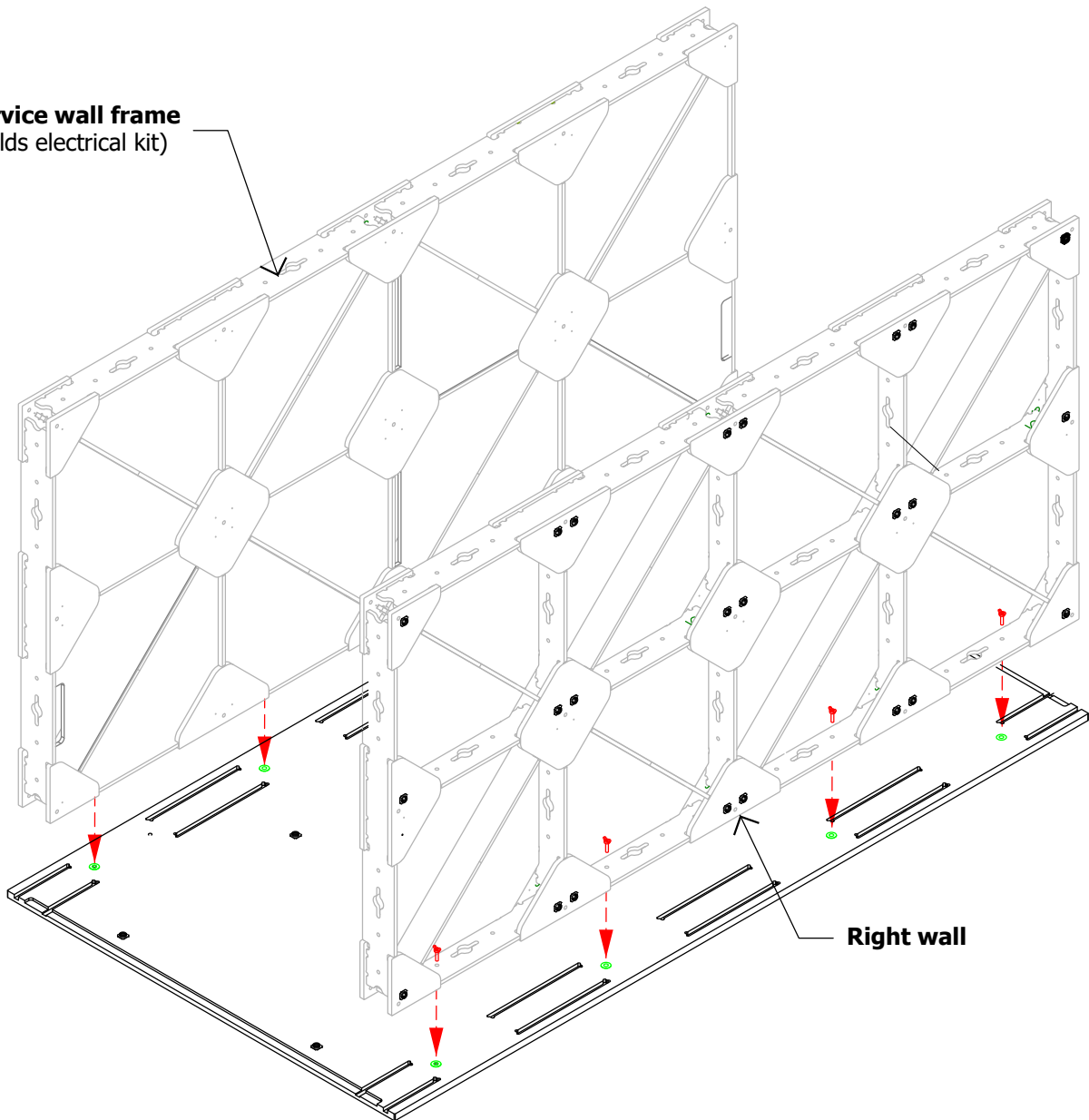

**Right wall**

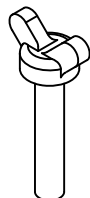

**25mm M6 Wing Screw x 8**



**32mm Penny Washers x 8**



## Step 2

### Connecting the floor and roof to the side walls.

**Step 2.1. Attach the base panel into the middle two insert nuts using 25mm Wing Screws and washers**

**Step 2.2. Attach the bottom 2 feet using 40mm Wing Screws and washers**

**Step 2.3. Attach the roof using 25mm Wing Screws and washers.**

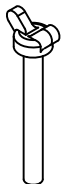
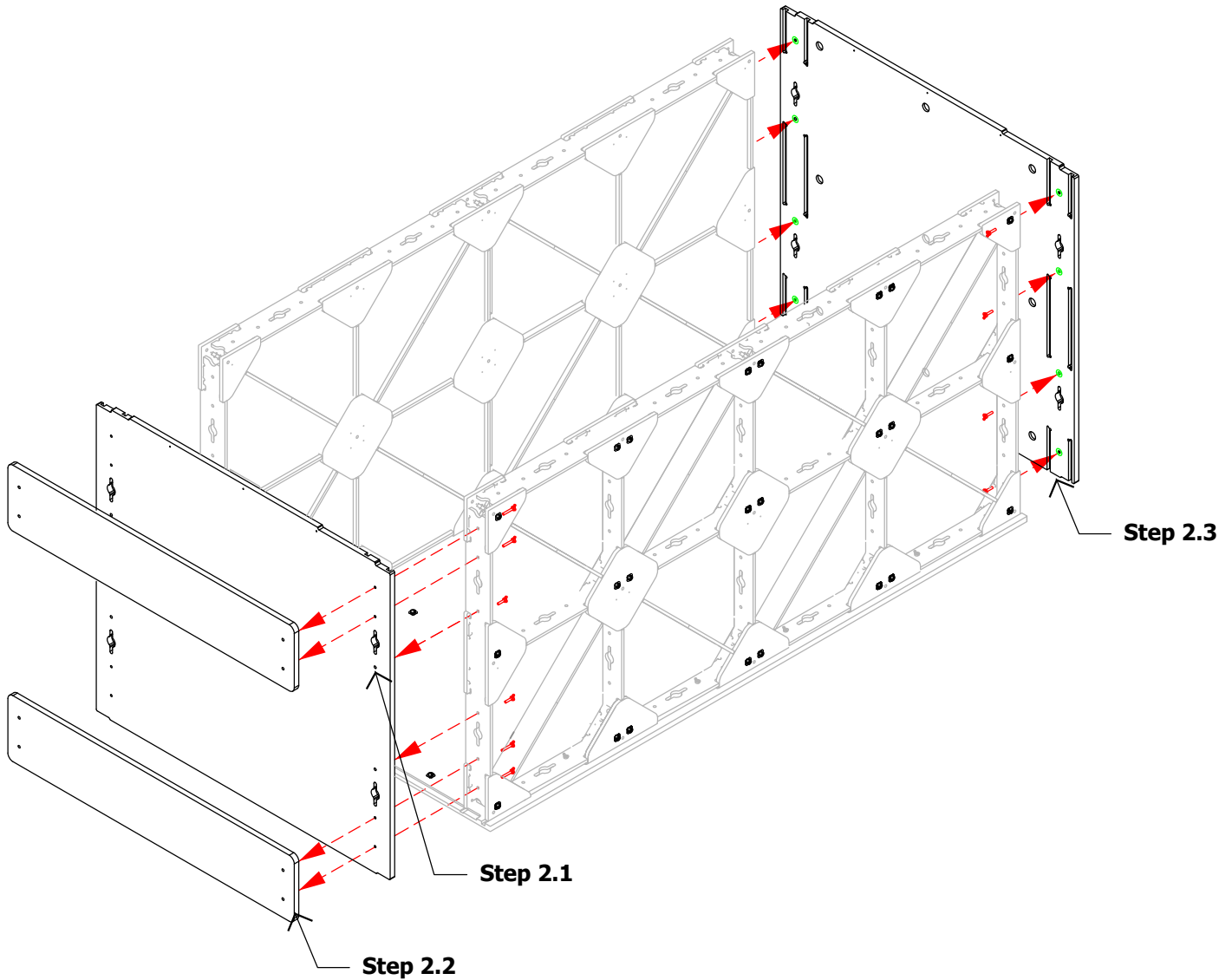

**40mm M6 Wing Screw x 4**



**25mm M6 Wing Screw x 10**



**32mm Penny Washers x 14**



# Step 3

## Connect side walls to back wall.

Push plywood end-capping into place. Attach Hinge capping using 25mm Wing Screws and washers. Attach Right wall's panels using 40mm Wing screws and washers.

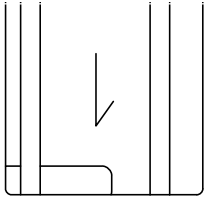

Note: the arrow on the bottom of the end cappings should point to the floor.

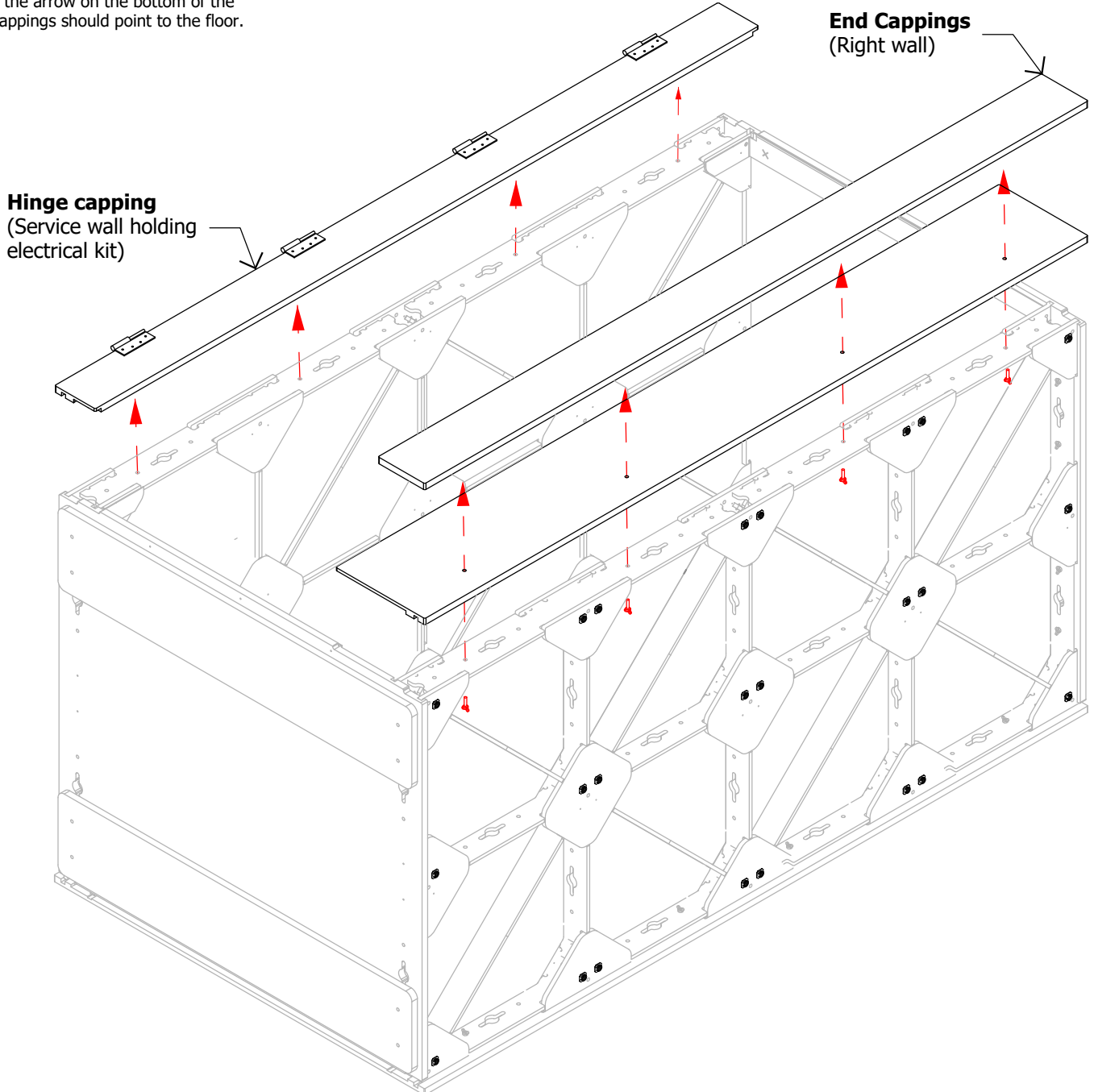

25mm M6 Wing Screw x 4

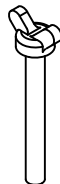

40mm M6 Wing Screw x 4

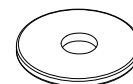

32mm Penny Washers x 8



## Step 4

Stand-up the booth.

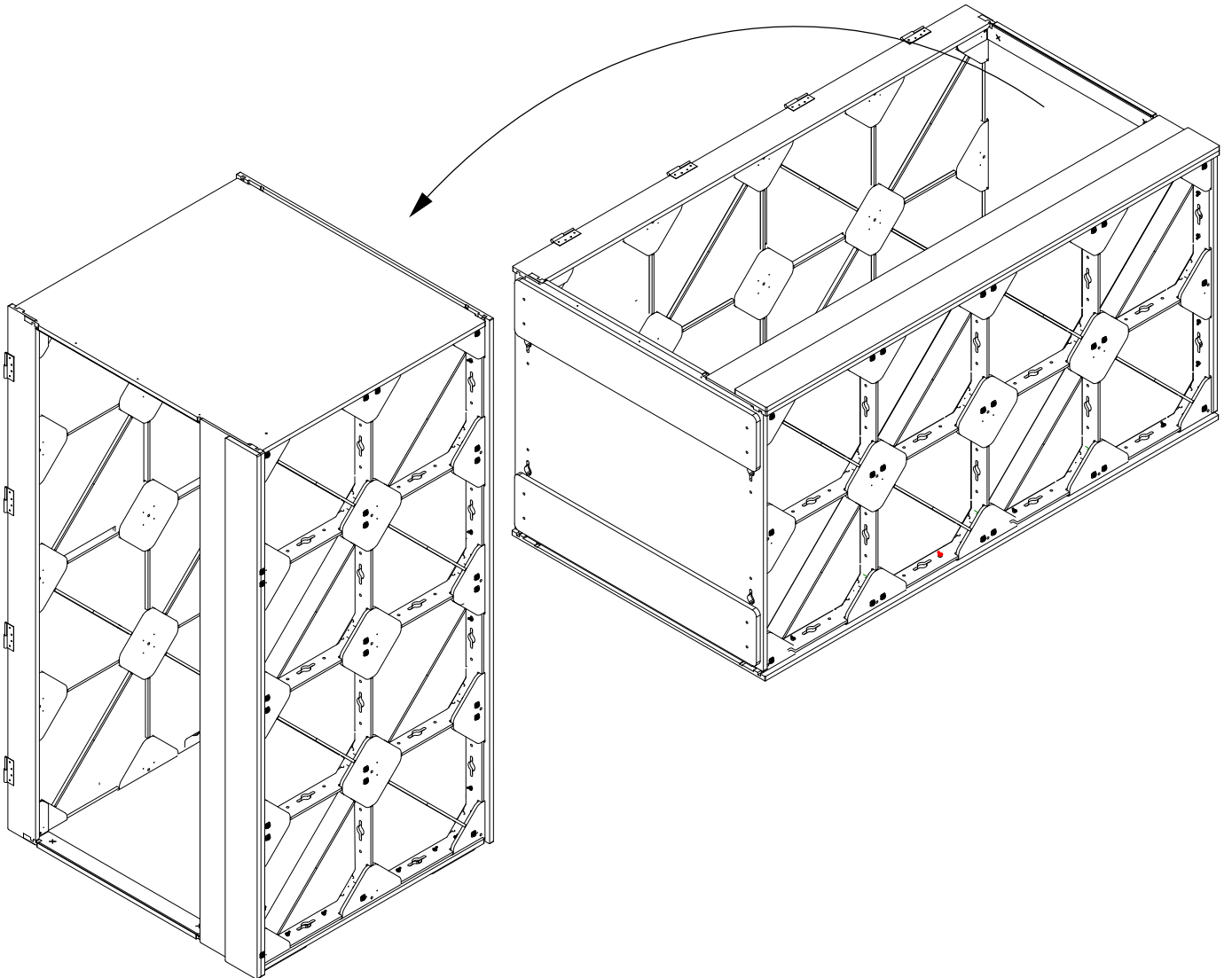

**Lift with 2 people  
and with care.**



# Step 5

## Install the desk.

Slot the desk in as pictured. Hold in place with 4x 50mm bolts. Use washers both sides. Ensure desk is slotted into back wall before bolting in-place.

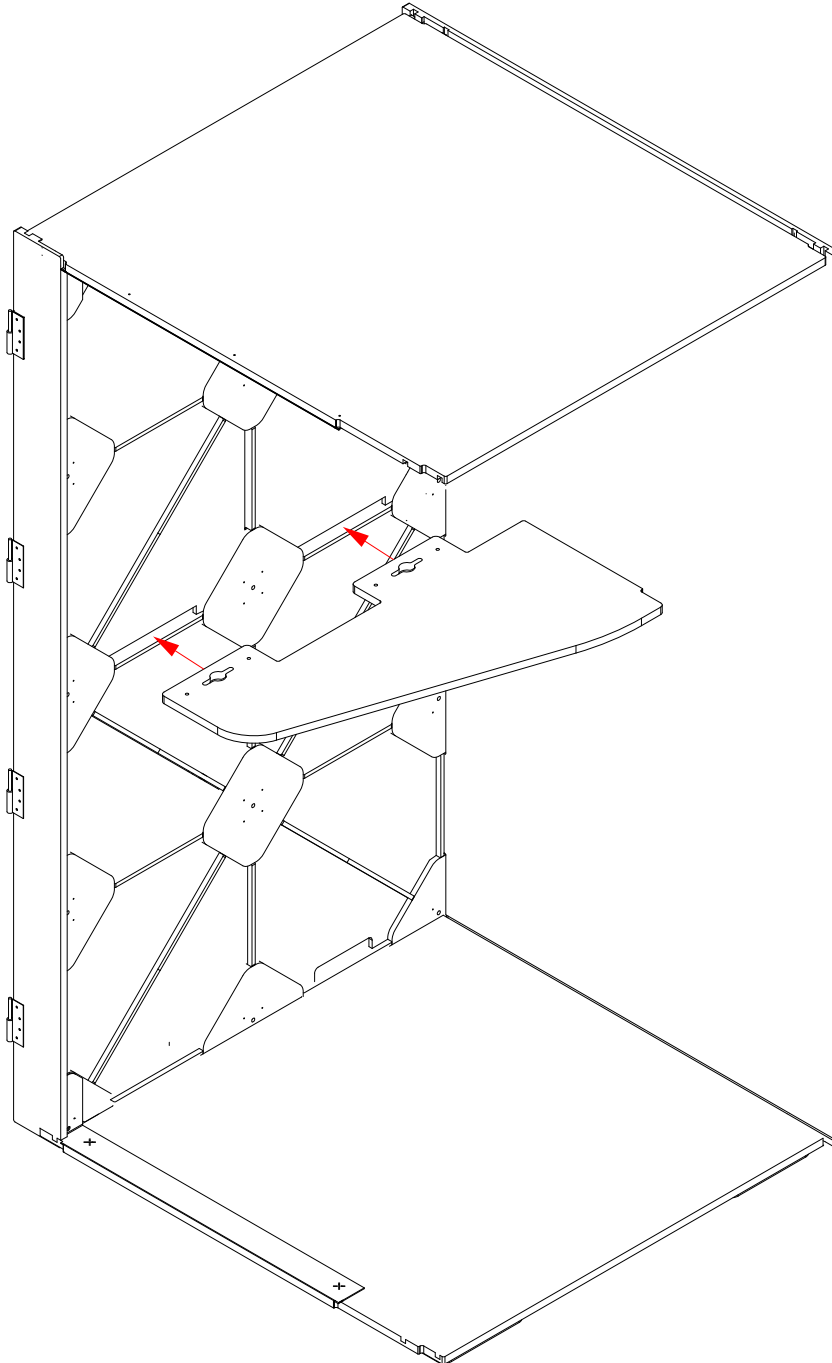

**4x 50mm M6 Bolt**



**4x M6 Hex screw nuts**

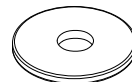

**32mm Penny Washers x 8**



# Step 6

Connect the electrical pass-through in the service wall.

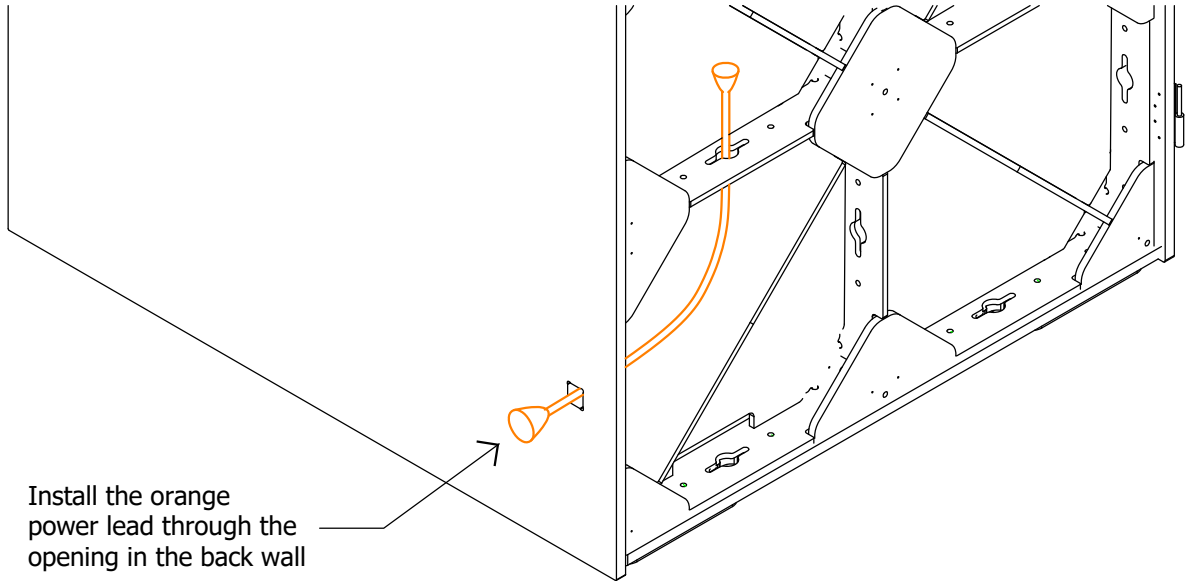

**Step 1:**  
Connect power lead into open socket

Step 2:  
Push the power plug into back wall lining and attach with 2 x 15mm screws black screws.

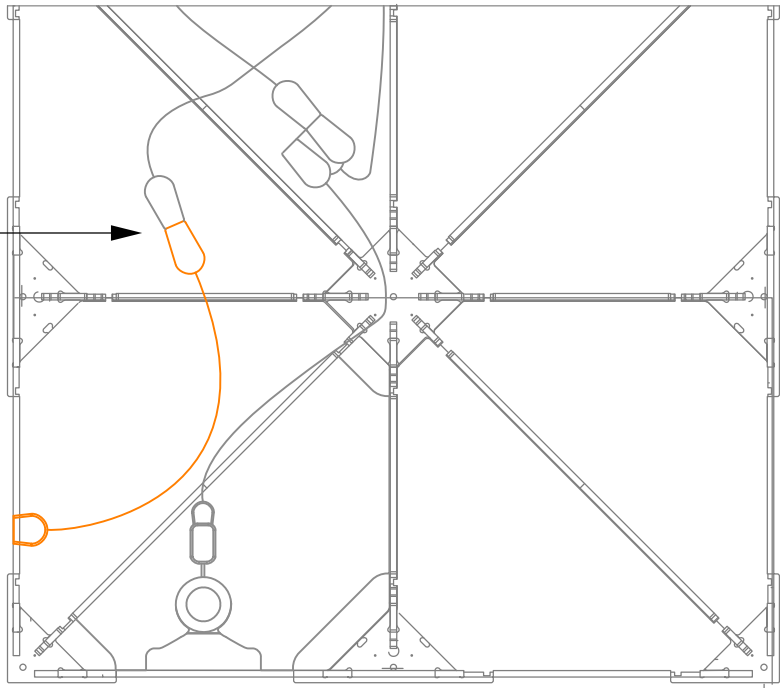

15mm Black Screw x 2





# Step 7

Re-install insulation.

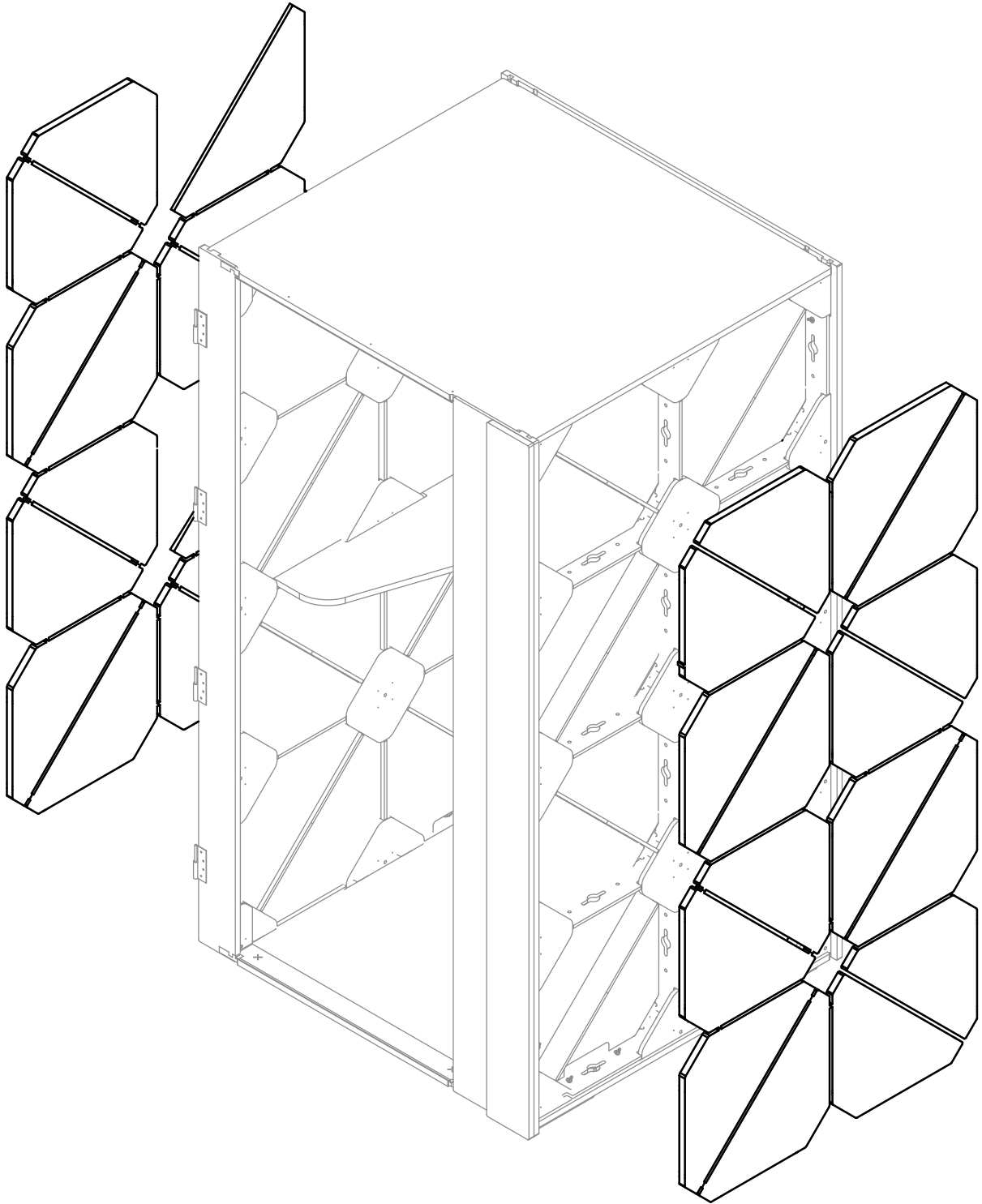



# Step 8

## Attach interior and exterior linings.

Press lining panels into the corresponding XFrame male clips on the booth frame. Note the orientation of the lining parts.  
**Note:** Lining for the interior back wall goes first, followed by the ceiling lining.

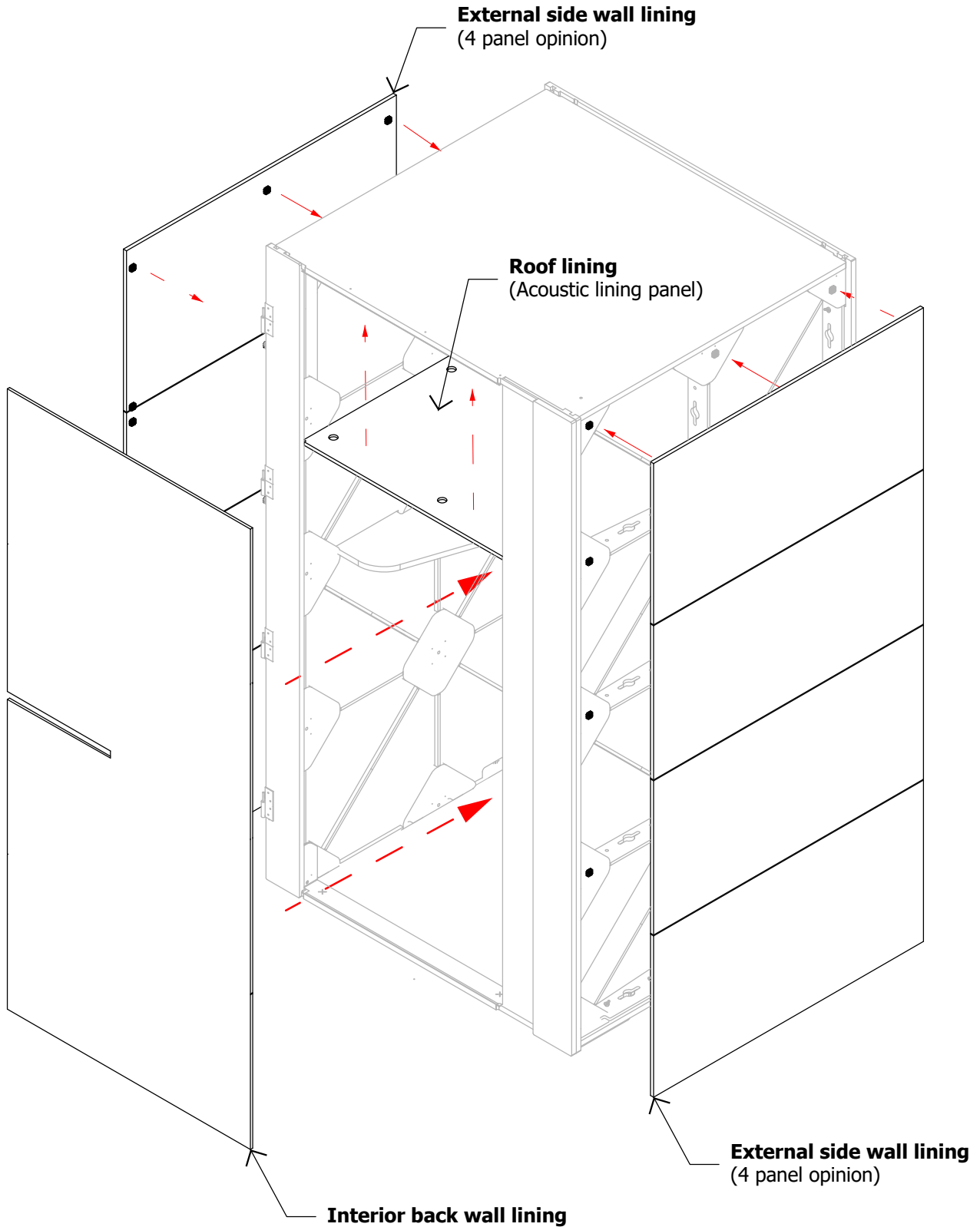



# Step 9

Attach the door onto corresponding hinges.

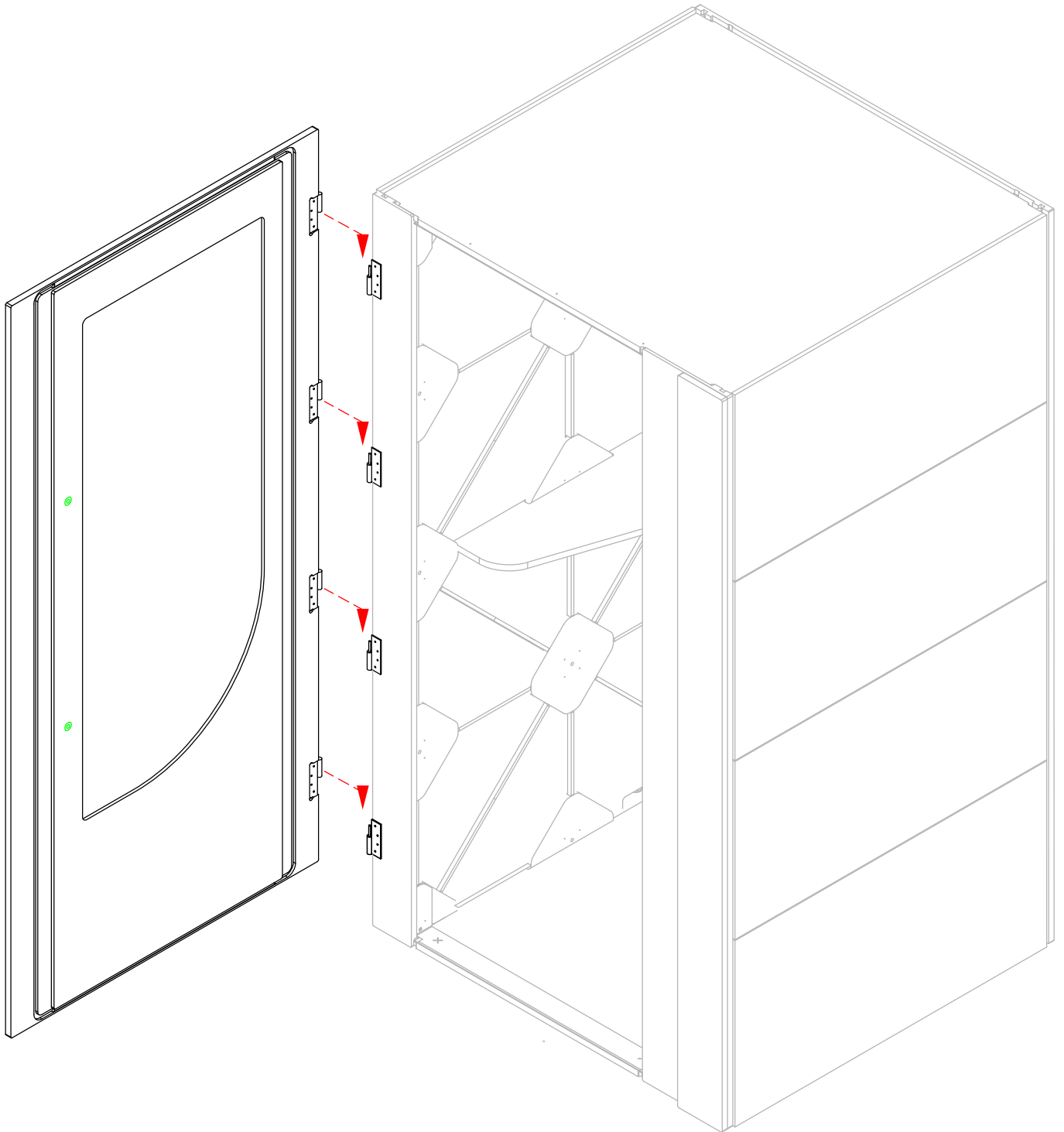



# Step 10

Attach door handles.

**Attach 40mm M6 Stand-Offs into the inset nuts in door frame.  
Then attach wooden handles with 35mm M6 JCBs.**

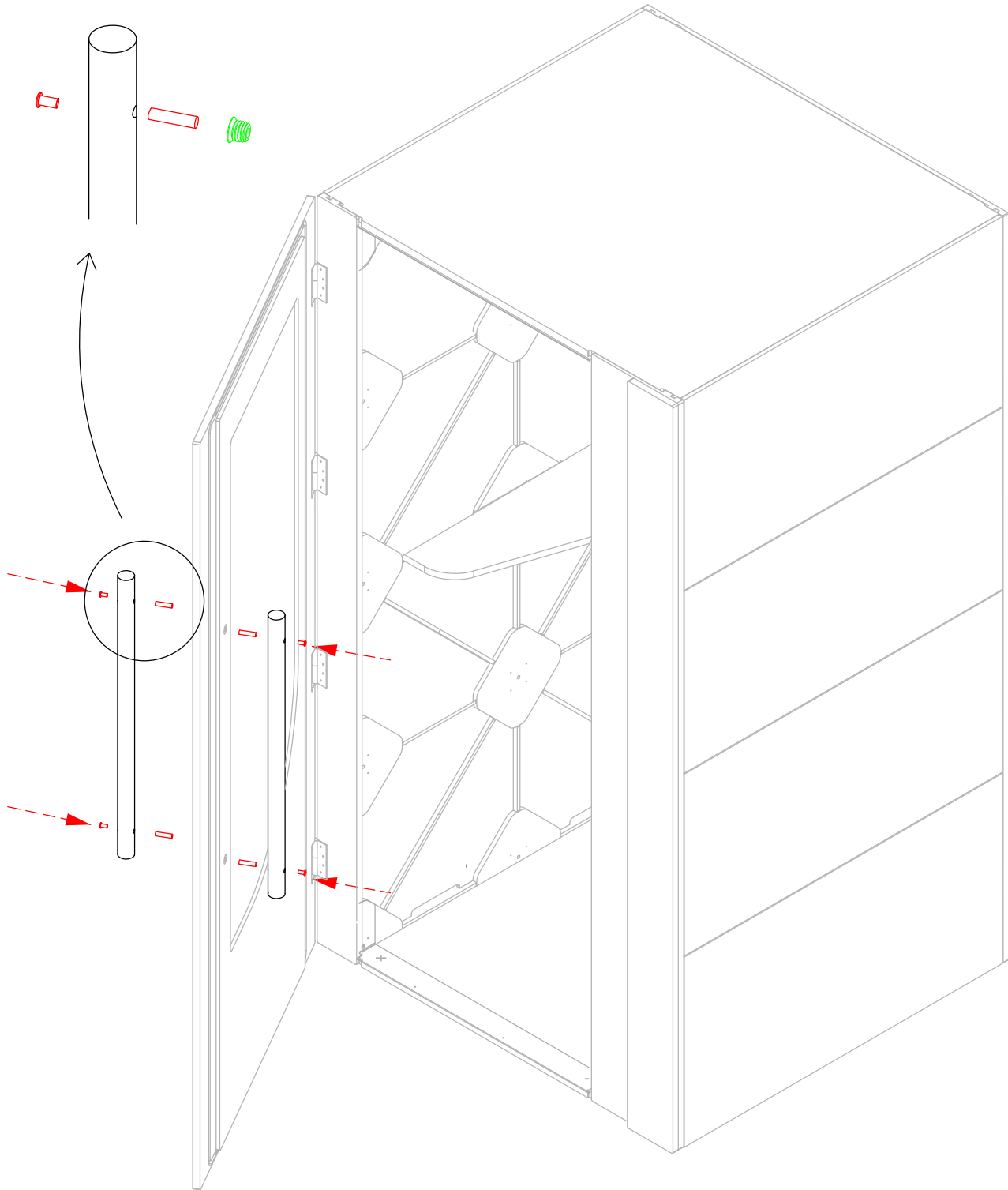

**40mm M6 Stand-Offs (ZP) x 4**

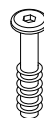

**35mm M6 JCB's x 4**



# Finished Assembled Product

Level as required in final position.

